



**Portable Carpet
Extractor
Owners Manual**



POWERFUL PRODUCTS FOR PROFESSIONAL CLEANING

Printed in Canada

ESTEAM CLEANING SYSTEMS

E600's

OWNER'S MANUAL

Congratulations on your selection of a new E600 soil extractor built in Canada by "Esteam Cleaning Systems." Our goal has been to produce the best high performance line of carpet cleaning equipment on the market today.

Reading your owners' manual will help to achieve maximum benefit from your purchase.

TABLE OF CONTENTS

	Page No.
Introduction to the E600	4
Specifications	5
Maintenance	6
Safety Information	7
Operating Instructions	9
Trouble Shooting	11
Schematic Diagram	15
Warranty Registration	29
Warranty	30

INTRODUCTION

Only the highest quality components go into our equipment, to deliver you strength and reliability in a long life, high performance machine. The E600's housing is made of high impact, unbreakable polyethylene. We are so confident in the housing that we put a lifetime warranty on this unit.

The E600's incorporate a unique 3 stage vacuum system to produce 125 inches of water lift. To compliment the vacuum lift the E600's come standard with a 100 PSI diaphragm demand pump. The E600 has an optional internal heater.

The E600's clean water solution tank and the dirty water recovery tank both have a 6 gallon capacity. Built into the recovery the E600's come standard with a high water automatic shut off. You never have to fear overfilling your recovery tank, as the vacuums will automatically stop extracting when the tank becomes full.

SPECIFICATIONS

E600's

ELECTRICAL	Single Cord 115 volt AC 15. Amp
VACUUMS	3 Stage vacuum motor
PUMP	100 PSI diaphragm demand pump
OPTIONAL HEATER	Boosts water temp. to 200°F
VACUUM LIFT	125" of water lift
SOLUTION TANK CAPACITY (clean water)	6 gallons
RECOVERY TANK CAPACITY	6 gallons
LENGTH	20 inches
WIDTH	16 inches
HEIGHT	28 inches
WEIGHT	55 lb.

MAINTENANCE

DAILY:

- Clean high-level water shut off screen inside recovery tank.
- Ensure automatic shut off float ball is working properly.
- Rinse out recovery tank after use.
- Clean dirt and obstructions from the (recovery tank) drain valve rubber gaskets to prevent premature wear.
- Rinse out pump with clean water at conclusion of workday.
- Clean poly housing with a mild soap and water.

MONTHLY:

- Clean air inlet and check exhaust port.

YEARLY:

- We recommend that your unit be inspected by a qualified service technician once a year.

PREVENTIVE MAINTENANCE:

Never store this unit in a place where there is a possibility of the temperature dropping below 0°C (32°F).

SAFETY INFORMATION

1. Prior to inspection or repair of this machine, disconnect all electrical cords rendering the machine powerless. Failure to do so could result in serious or fatal injury.
2. Inspect unit daily for worn or damaged components e.g. frayed cord, loose plug, or a plug with missing ground pin, etc.
3. This unit should only be operated when in an upright position on a level surface.
4. Do not operate unit unless it is properly grounded in a 3 pin grounded outlet. Never bend or remove ground pin from plug.
5. Ensure filters and screens are free from lint or dirt.
6. Do not run unit if vacuum motors or pump are wet. Allow sufficient time for motors to dry before plugging unit in.
7. Do not use solvent-based cleaning products in this extractor.
8. Keep air inlet and exhaust ports free from obstructions. Blocked air inlets or exhaust ports can cause the unit to over heat.
9. Do not use solution or recovery tanks for storing hoses, cords, or accessories.
10. When using electrical equipment around water it is important to wear rubber-soled shoes and keep machine properly grounded at all times. Failure to do so could result in a fatal electric shock.

E600 MODELS



E600 & E600-20 MODELS



E600-10 & E600-20-10 MODELS



OPERATING INSTRUCTIONS

1. Premix cleaning solution with hot water in a 20 litre pail. Pour mixed solution in solution tank of unit.

NOTE: Do not mix more solution than you will need for the job.

2. Connect vacuum and solution hoses to unit.
3. Insert plug into 3 pin grounded outlet. Try to use an outlet in a hallway or adjoining room in order to keep electrical cord out of your way.
4. We recommend the use of a liquid defoamer, to prevent the machine from prematurely shutting off due to excess foam in the recovery tank. Turn on vacuums and pour approximately $\frac{1}{4}$ cup of Esteam Liquid Defoamer into the end of the vacuum hose.

5. Connect vacuum and solution hoses to carpet cleaning wand.

6. Proceed to clean carpets.

NOTE: To prevent over wetting we recommend two dry passes (vacuum only) for every one wet pass (applying solution to carpet).

7. When the recovery tank becomes full, vacuums will automatically stop extracting. When the vacuums have stopped extracting they will make a distinctive high-pitched noise, as all airflow will be cut off. At this time switch unit off. Drain the recovery tank by pulling up on drain valve on front of machine.

NOTE: Ensure that the automatic high water shut off screen inside recovery tank is free from any obstructions. Be sure to close drain valve before resuming cleaning.

8. To empty solution tank remove vacuum hose from wand. Turn one vacuum on and extract extra solution from solution tank into recovery tank, then drain recovery tank.

NOTE: Do not completely submerge end of vacuum hose into solution. Allow some air to enter end of vacuum hose with liquid.

OPERATING INSTRUCTIONS (CONTINUED)

9. When the job is completed, empty and rinse out the solution and recovery tanks. Allow vacuum to run for 3 to 5 minutes. This will eliminate all moisture from vacuums assuring long vacuum life.

WARNING: When using electrical equipment around water, it is important to wear rubber-soled shoes and keep machine properly grounded at all times. Failure to do so could result in a fatal electric shock.

TROUBLE SHOOTING

WARNING: Prior to inspection or repair of this machine, disconnect all electrical cords rendering the machine powerless. Failure to do so could result in serious or fatal injury.

PROBLEM	CAUSE	SOLUTION
1. Entire unit will not operate	1. Unit not plugged in	1. Connect unit to 3 pin grounded outlet
	2. Blown fuse or breaker for plug outlet	2. Check fuse panel for blown fuse
	3. Loose wiring	3. See dealer
2. Pump will not run	1. Switch not turned on	1. Turn on switch
	2. Kink in solution hose	2. Remove kink
	3. Plugged jet or quick connect	3. Remove blockage
	4. Broken Switch	4. See dealer
	5. Loose wiring	5. See dealer
	6. Pump defective	6. See dealer
3. Vacuums will not run	1. Switch not turned on	1. Turn on switch
	2. Broken switch	2. See dealer
	3. Loose wiring	3. See dealer
	4. Blocked Rotor	4. See dealer

TROUBLE SHOOTING (CONTINUED)

<u>PROBLEM</u>	<u>CAUSE</u>	<u>SOLUTION</u>
4. Pump runs but does not pump solution	1. Out of solution	1. Fill with solution
	2. Pump inlet screen plugged	2. Clean inlet screen
	3. Pump was not properly primed	3. Prime pump using priming hose
	4. Internal or external solution line damaged and leaking	4. See dealer
5. Pump runs but has loss of pressure	1. Partial kink in solution hose	1. Remove kink
	2. Jet orifice opening on cleaning wand is too large	2. Total jet opening for 100 PSI should be .06 or .08
	3. Internal pump components wearing out	3. See dealer
	4. NOTE: Operation of pump using wand or hand tool with an orifice opening less than .06 will cause pump to cavitate and could result in premature wear of pump components.	

TROUBLE SHOOTING (CONTINUED)

PROBLEM	CAUSE	SOLUTION
6. Vacuums operate but have poor or no suction	1. Recovery tank full	1. Drain recovery tank
	2. Vacuum hose plugged	2. Remove blockage
	3. Wand plugged	3. Remove blockage
	4. Exhaust port blocked	4. Remove blockage
	5. High level shut off float stuck in off position	5. Turn vacuum off and tap top of float screen cage
	6. Front drain valve left open after draining recovery tank	6. Close recovery tank drain valve on front of machine
7. Vacuums prematurely stop extracting	1. Excess foam in recovery tank	1. Add defoamer to recovery tank
	2. Lint or dirt on high level shut off float screen	2. Clean high level shut off float screen
	3. Defective float ball	3. Replace float screen cage
8. Machine spits water out of exhaust port	1. High level shut off float not working properly	1. Check high level shut off float cage and ball for proper operation
	2. Foam build up in recovery tank	2. Add defoamer to recovery tank
9. Machine blowing excessive amounts of water out of exhaust ports	1. Damaged (leaking) recovery tank fittings	1. Immediately shut unit down. Bring to a dealer for service

TROUBLE SHOOTING (CONTINUED)

PROBLEM	CAUSE	SOLUTION
10. Water accumulating in bottom electrical component area	1. Inside solution line leaking	1. Immediately shut unit down. Bring unit to a dealer for service
	2. Pump leaking	2. Immediately shut unit down. Bring unit to a dealer for service
	3. Solution or recovery tank leaking from above	3. Immediately shut unit down. Bring unit to a dealer for service

E600 & E600-20 MODELS

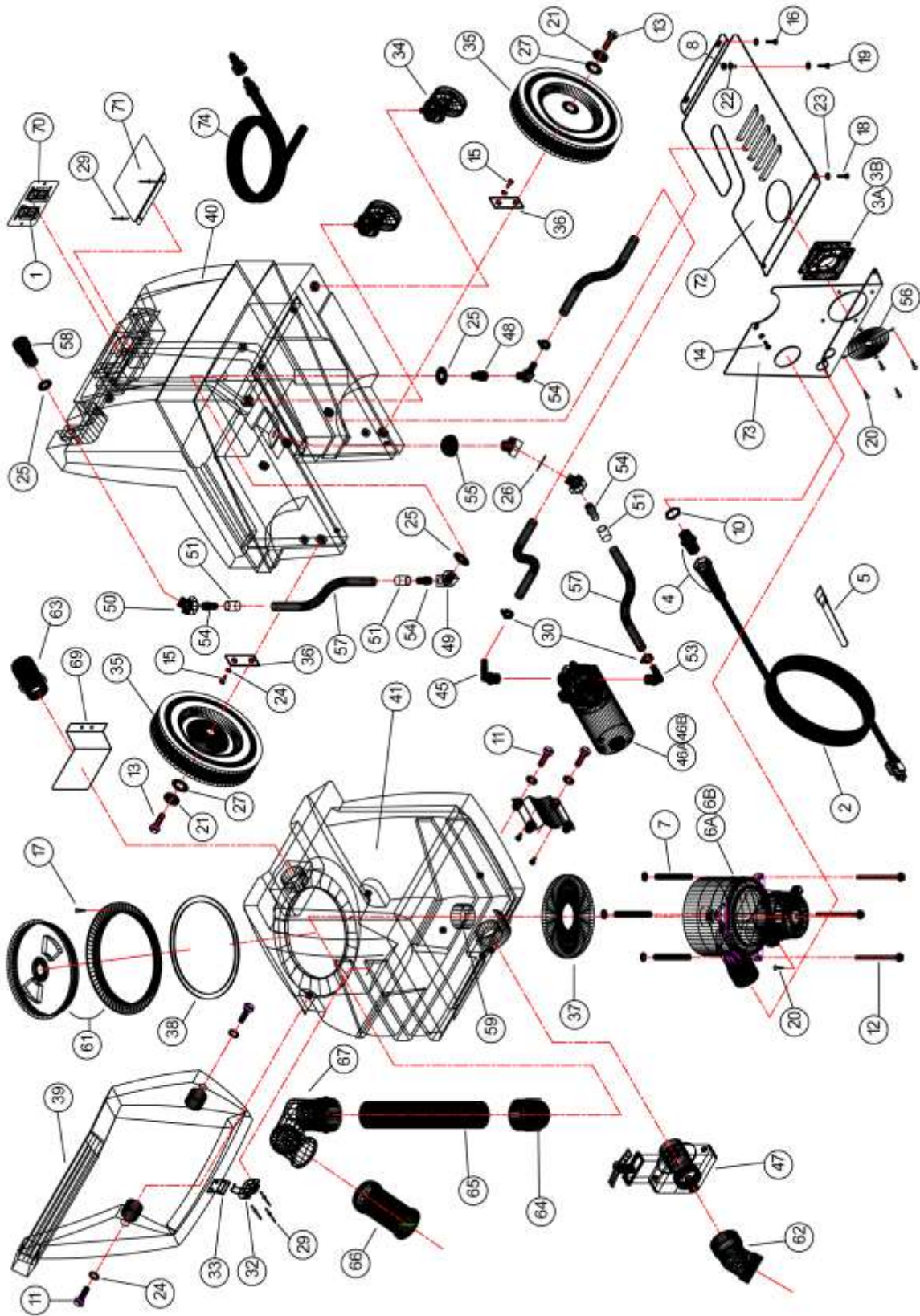

E600 & E600-20 PART LISTS

REF	PART NO.	DESCRIPTION	NOTES:
1	305-230	Switch, Rocker 20 Amp	
2	315-015	Cord, 25' Black 14/3 SJTW-A	
3A	333-005	Fan Muffin 4" 110v	E600
3B	333-006	Fan Muffin 4" 220v	E600-20
4	335-015	Strain Relief, 16 Gauge	
5	350-005	Strap Velcro	
6A	355-550	Vacuum, 3 Stg 110v	E600
6B	355-510	Vacuum, 3 Stg 220v	E600-20
7	355-219	Vac Spacer 5/16 x 3	
8	400-130	Locknut, 10 x 24 Nylon SS	
9	400-148	Locknut, 4 x 40 Nylon SS	Not shown
10	400-165	Locknut, 1/2"	
11	405-005	Bolt, 1/4 x 3/4 GR5 Zinc	
12	405-060	Bolt, 1/4 x 4 GR5 Zinc	
13	405-521	Bolt Shoulder 3/8 x 2 1/4	
14	405-615	CS, 1/4 x 1/2 SS (Hex HD)	
15	405-620	CS, 1/4 x 3/4 SS (Hex HD)	
16	410-100	MS, 8-32 x 1/4 Pan PH SS	
17	410-125	SMS, 8 x 5/8 Pan Rob. S.S.	
18	410-130	MS, 8-32 x 1/2 Pan PH SS	
19	410-160	MS, 10-24 x 3/4 Pan PH SS	
20	410-225	SMS, 10 X 1/2 Pan Rob. Zinc	
21	415-050	LW, 1/2 Zinc	
22	415-052	Star Washer External # 10	
23	415-115	FW, 10 SS	
24	415-125	FW, 1/4 SS	
25	415-155	FW, 1/2 SS (Stand/Max OD)	
26	415-156	FW, 1/2 SS	
27	415-157	FW, 1/2 AN SS	
28	415-305	FNDW, 1/4 SS	Not shown
29	420-151	Rivet, AL/AL Fullysealed #68	
30	425-115	Clamp, Hose Silicone	
31	435-040	Handwheel, Cross M	Not shown
32	445-012	Latch	
33	445-013	Keeper	
34	455-010	Caster, 2 1/2	
35	455-057	Wheel, 8" Grey\Black Hub	
36	465-055	BRKT, Wheel – E600	
37	475-035	Gasket, Vac 5 3/4	
38	475-125	Gasket 6" Access Cover-Clear	
39	495-430	Handle E600 (NBLK)	
40	495-435	Sol Tank E600 (NBLK)	
41	495-440	Rec Tank E600 (NB)	
42	498-055	Plug, 1/2 Nylon	Not shown

43	498-060	Plug, 3/4 Nylon	Not shown
44	498-065	Plug, 7/8 Nylon	Not shown
45	510-090	Elbow, 90 Non-SWL (FEM. Port)	
46A	511-100	Pump, 100 PSI, 110v	E600
46B	511-300	Pump, 100 PSI, 220v	E600-20
47	545-100	Dump Valve, 1 1/2"	
48	555-002	ADPT, 1/4 M x 1/4 FM	
49	555-182	Elbow 45, 1/4 FEM. Extruded	
50	555-184	Elbow 45, Street 1/4	
51	555-254	Ferrule, 3/8 Hose	
52	555-324	Hose Barb 90, 3/8 Barb x 1/4 MPT	
53	555-326	Hose Barb 90, 3/8 Barb x 3/8 MPT	
54	555-364	Hose Barb, 3/8 Barb x 1/4 MPT	
55	560-030	Screen, Acorn	
56	560-325	Guard, Finger 4" Muffin Fan	
57	572-041	L.P. Hose 3/8"	
58	580-010	Q.C. 1/4" Fem (Closed)	
59	585-025	Spin Fitting, 1 1/2	
60	585-045	Nylon Spacer 1/4	Not shown
61	585-215	Lid Assy Waste Tank 6"	
62	588-020	ABS Elbow 45, 1 1/2 SLP x SLP	
63	590-405	PVC Hose Barb 1 1/2" x MPT	
64	590-415	PVC Adpt 1 1/2", S x MPT	
65	595-005	ABS Pipe, 1 1/2"	
66	597-010	Float Screen Cage - Sealed	
67	597-061	Adpt (RM) 30 Degree	
68	703-332	Plate Decal	Not shown
69	845-020	Baffle, S/S	
70	845-035	Switch Plate	
71	845-055	Solution Tank Cover	
72	845-060	Access Plate, Bottom	
73	845-065	Access Plate, Back	

E600-10 & E600-20-10 MODELS

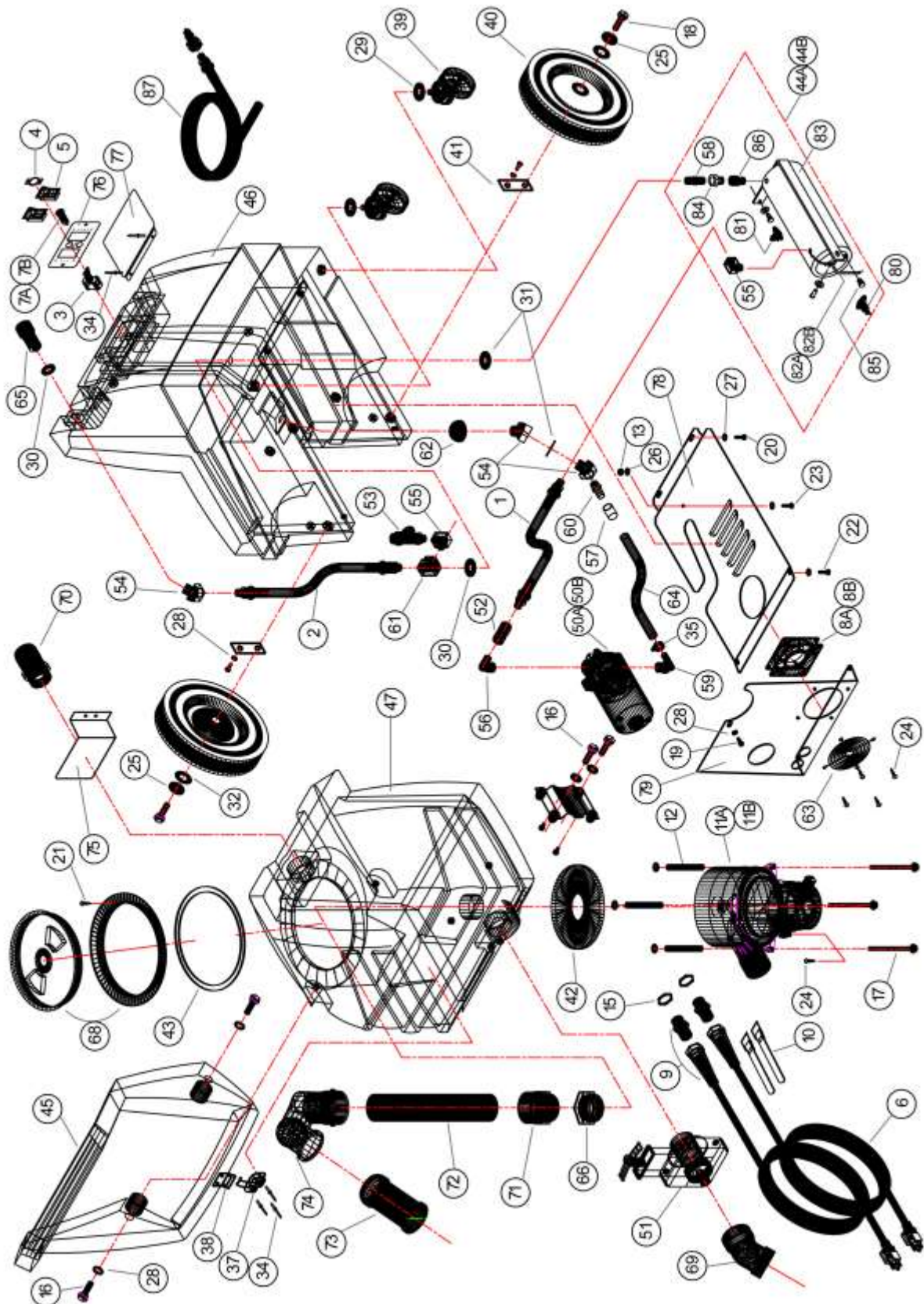

E 600-10 & E600-20-10 PART LISTS

REF	PART NO.	DESCRIPTION	NOTES:
1	263-007	HP Hose 12"	
2	263-008	HP Hose 18"	
3	305-210	Toggle Switch	
4	305-225	Switch Plate ON/OFF	
5	305-230	Switch, Rocker 20 Amp	
6	315-015	Cord, 25' Black 14/3 SJTW-A	
7A	320-110	Lamp, Panel 110v	E600-10
7B	320-900	Lamp, Panel 220v	E600-20-10
8A	333-005	Fan Muffin 4" 110v	E600-10
8B	333-006	Fan Muffin 4" 220v	E600-20-10
9	335-015	Strain Relief, 16 Gauge	
10	350-005	Strap Velcro	
11A	355-550	Vacuum, 3 Stg 110v	E600-10
11B	355-500	Vacuum, 3 Stg 220v	E600-20-10
12	355-219	Vac Spacer 5/16 x 3	
13	400-130	Locknut, 10 x 24 Nylon SS	
14	400-148	Locknut, 4 x 40 Nylon SS	Not shown
15	400-165	Locknut, 1/2"	
16	405-005	Bolt, 1/4 x 3/4 GR5 Zinc	
17	405-060	Bolt, 1/4 x 4 GR5 Zinc	
18	405-521	Bolt Shoulder 3/8 x 2 1/4	
19	405-615	CS, 1/4 x 1/2 SS (Hex HD)	
20	410-100	MS, 8-32 x 1/4 Pan PH SS	
21	410-125	SMS, 8 x 5/8 Pan Rob. S.S.	
22	410-130	MS, 8-32 x 1/2 Pan PH SS	
23	410-160	MS, 10-24 x 3/4 Pan PH SS	
24	410-225	SMS, 10 X 1/2 Pan Rob. Zinc	
25	415-050	LW, 1/2 Zinc	
26	415-052	Star Washer External # 10	
27	415-115	FW, 10 SS	
28	415-125	FW, 1/4 SS	
29	415-138	3/8 Fender Washer S.S.	
30	415-155	FW, 1/2 SS (Stand/Max OD)	
31	415-156	FW, 1/2 SS	
32	415-157	FW, 1/2 AN SS	
33	415-305	FNDW, 1/4 SS	Not shown
34	420-151	Rivet, AL/AL Fullysealed #68	
35	425-115	Clamp, Hose Silicone	
36	435-040	Handwheel, Cross M	Not shown
37	445-012	Latch	
38	445-013	Keeper	
39	455-010	Caster, 2 1/2	
40	455-057	Wheel, 8" Grey\Black Hub	
41	465-055	BRKT, Wheel – E600	
42	475-035	Gasket, Vac 5 3/4	
43	475-125	Gasket 6" Access Cover-Clear	

44A	490-002	Heater Mate Foamed Casing 110V	E600-10
44B	490-003	Heater Mate Foamed Casing 220V	E600-20-10
45	495-430	Handle E600 (NBLK)	
46	495-435	Sol Tank E600 (NBLK)	
47	495-440	Rec Tank E600 (NB)	
48	498-055	Plug, 1/2 Nylon	Not shown
49	498-060	Plug, 3/4 Nylon	Not shown
50A	511-100	Pump, 100 PSI, 110v	E600-10
50B	511-300	Pump, 100 PSI, 220v	E600-20-10
51	545-100	Dump Valve, 1 1/2"	
52	550-035	Check valve 1/4	
53	551-015	Pressure Limiter, 175 PSI	
54	555-184	Elbow 45, Street 1/4	
55	555-208	Elbow 90, 1/4 Street Extruded	
56	555-210	Elbow 90, 3/8 MPT x 1/4 MPT	
57	555-254	Ferrule, 3/8 Hose	
58	555-272	Hex Nipple, 1/4 Long	
59	555-326	Hose Barb 90, 3/8 Barb x 3/8 MPT	
60	555-364	Hose Barb, 3/8 Barb x 1/4 MPT	
61	555-634	Tee 1/4 FPT	
62	560-030	Screen, Acorn	
63	560-325	Guard, Finger 4" Muffin Fan	
64	572-041	L.P. Hose 3/8"	
65	580-010	Q.C. 1/4" Fem (Closed)	
66	585-025	Spin Fitting, 1 1/2	
67	585-045	Nylon Spacer 1/4	Not shown
68	585-215	Lid Assy Waste Tank 6"	
69	588-020	ABS Elbow 45, 1 1/2 SLP x SLP	
70	590-405	PVC Hose Barb 1 1/2" x MPT	
71	590-415	PVC Adpt 1 1/2", S x MPT	
72	595-005	ABS Pipe, 1 1/2"	
73	597-010	Float Screen Cage - Sealed	
74	597-061	Adpt (RM) 30 Degree	
75	845-020	Baffle, S/S	
76	845-035	Switch Plate	
77	845-055	Solution Tank Cover	
78	845-060	Access Plate, Bottom	
79	845-065	Access Plate, Back	
80	305-245	Thermo Cut/Out	
81	305-265	Thermostat 200F	
82A	318-005	Cartridge, 110V, 1850 W	E600-10
82B	318-900	Cartridge, 220V, 1850 W	E600-20-10
83	490-016	Casing, RND Heater	
84	555-024	Bushing, 3/8M x 1/4FM	
85	555-451	Plug, 1/8 Hex	
86	555-512	Reducing ADPT, 3/8 FPT x 1/4 MPT	
87	263-105	Prime Line 4'	

;

ESTEAM PUMP 100 PSI

ESTEAM 100 PSI PUMP KITS
511-215 UPPER HOUSING ASSY
511-225 VALVE ASSY
511-235 LOWER HOUSING ASSY
511-205 PRESSURE SWITCH

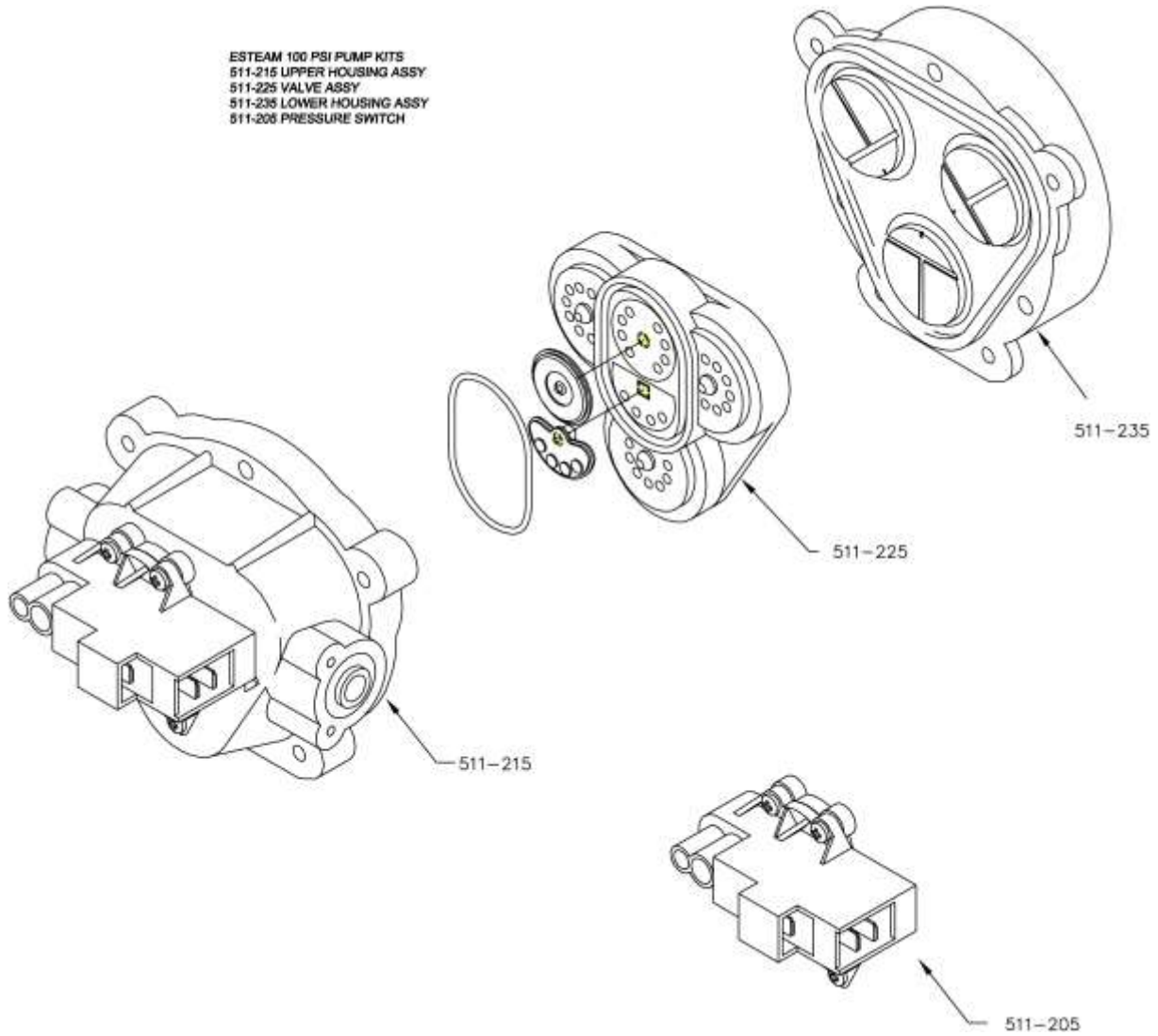

PUMP TROUBLE SHOOTING GUIDE

TROUBLE	PROBABLE CAUSE	TO CORRECT
Pump starts but no prime	<ol style="list-style-type: none"> 1. Not enough volt 2. No liquid 3. Leak in inlet line 4. Air lock 5. Bad valves 6. Mounted too high 7. Check valve stuck 8. Debris in pump 9. Clogged filter 10. Line connection backward 11. Missing VLV. HSG O-ring 	<ol style="list-style-type: none"> 1. Provide correct volt 2. Fill liquid 3. Correct leak 4. Bleed air 5. Replace valves 6. Lower mounting 7. Clean/replace ck. Valve 8. Clean/replace damaged parts 9. Clean/replace filter 10. Connect line to proper port 11. Replace O-ring
External Leak from pump head drain	<ol style="list-style-type: none"> 1. Ruptured diaphragm 2. Piston SC loose 3. Pinched diaphragm 4. Cross thread piston scr. 	<ol style="list-style-type: none"> 1. Replace diaphragm 2. Tighten Piston screw 3. Replace diaphragm 4. Properly assemble
External leak from switch	<ol style="list-style-type: none"> 1. Ruptured SW diaphragm 2. Pinched SW diaphragm 3. Loose switch screw 	<ol style="list-style-type: none"> 1. Replace SW diaphragm 2. Replace SW diaphragm 3. Secure switch screw
Vacuum leak	<ol style="list-style-type: none"> 1. Pinched diaphragm 2. Cracked upper hsg 3. Loose inline fitting 4. Cracked valve housing 	<ol style="list-style-type: none"> 1. Replace diaphragm 2. Replace upper housing 3. Tighten fitting 4. Replace valve housing
Rough pump	<ol style="list-style-type: none"> 1. Bad motor 2. Bad drive 3. Screws loose 	<ol style="list-style-type: none"> 1. Replace 2. Replace 3. Tighten screws
Low performance	<ol style="list-style-type: none"> 1. Clogged filter 2. Bad motor 3. Improper voltage 4. Bad valves 5. Improper plumbing 6. Loose fasteners 	<ol style="list-style-type: none"> 1. Clean/replace 2. Replace 3. Provide proper voltage 4. Replace 5. Correct plumbing 6. Secure all fasteners

PUMP TROUBLE SHOOTING GUIDE

TROUBLE	PROBABLE CAUSE	TO CORRECT
Pump will not start	<ol style="list-style-type: none">1. Bad motor2. Bad rectifier3. Bad wire connection4. Bad micro switch5. Bad brushes6. Frozen drive7. Blown fuse8. No power to pump	<ol style="list-style-type: none">1. Replace2. Replace motor3. Correct connection4. Replace5. Replace motor6. Replace drive7. Replace8. Connect power
No shut off	<ol style="list-style-type: none">1. No Liquid2. Air lock3. Shut set too high (By-pass SW combination)4. Bad micro switch	<ol style="list-style-type: none">1. Fill liquid2. Purge line check installation3. Set to correct shutoff4. Replace

INTERNAL HEATER MATE

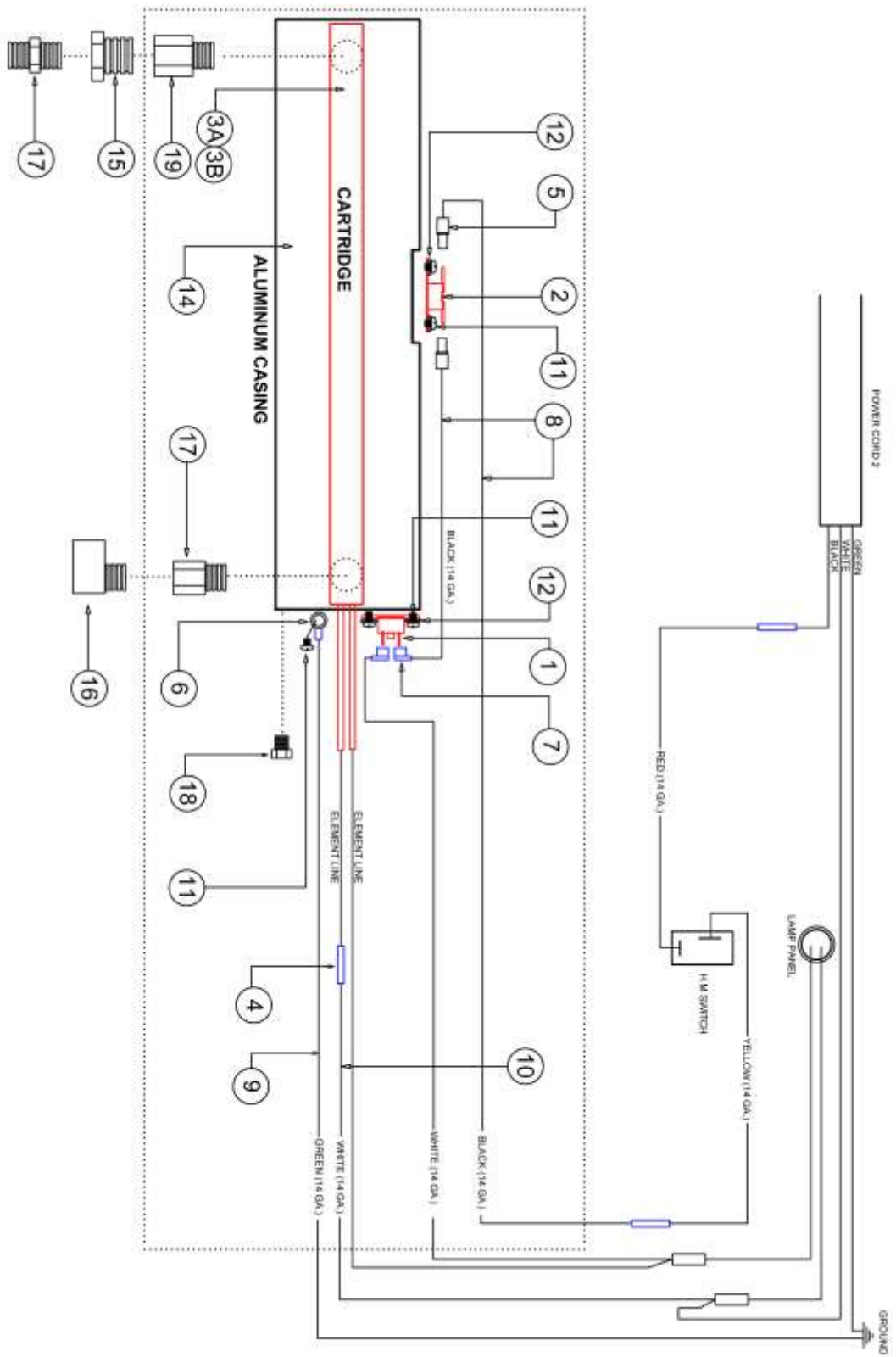

INTERNAL HEATER MATE (490-002/490-003)

REF	PART NO.	DESCRIPTION	NOTES:
1	305-245	Thermo Cut-Out	
2	305-265	Thermostat 200F	
3A	318-005	Heater Element 1850W 110V	Use For 490-002
3B	318-900	Heater Element 1850W 220V	Use For 490-003
4	325-005	Connector, Butt - Blue	
5	325-120	Spade, 3/16 F - Blue	
6	325-230	Terminal Ring, #10 - Blue	
7	325-500	Spade, 1/4 FEM. 90 Crimp	
8	330-225	Wire, 14 GA - Black	
9	330-230	Wire, 14 GA - Green	
10	330-235	Wire, 14 GA - White	
11	410-070	MS, 6 x 3/16 Pan PHL	
12	415-005	LW, 6 Zinc	
13	475-070	Gasket 1/8"	Not shown
14	490-016	Alum (Round) Casing	
15	555-024	Bushing, 3/8 M x 1/4 F	
16	555-208	Elbow 90, 1/4" Street Extruded	
17	555-272	Hex Nipple, 1/4"	
18	555-451	Plug, 1/8 Hex	
19	555-512	Reducing ADPT, 3/8 FPT x 1/4 MPT	

E600 WIRING

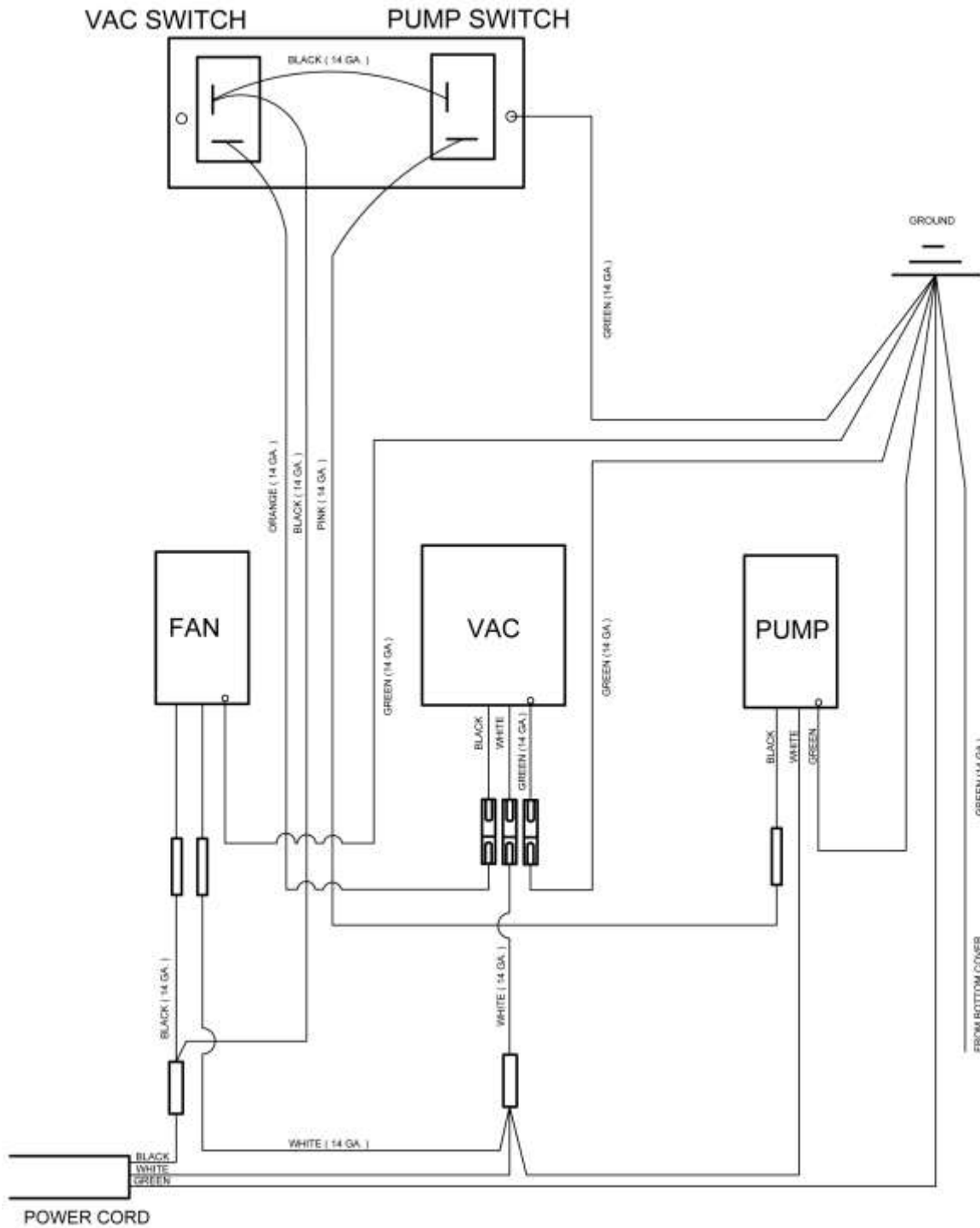

E600 HEATER MATE WIRING P.1

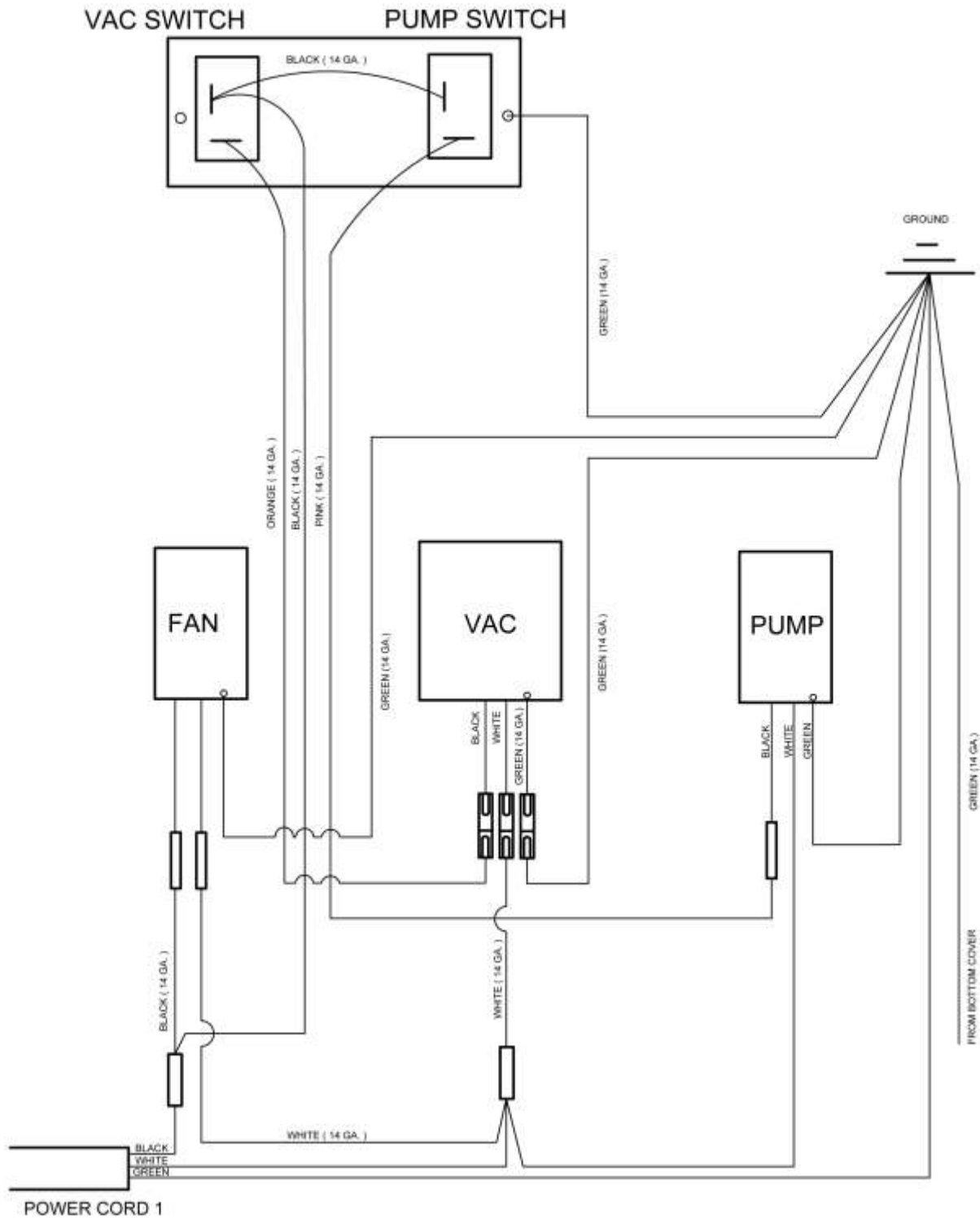

E600 HEATER MATE WIRING P.2

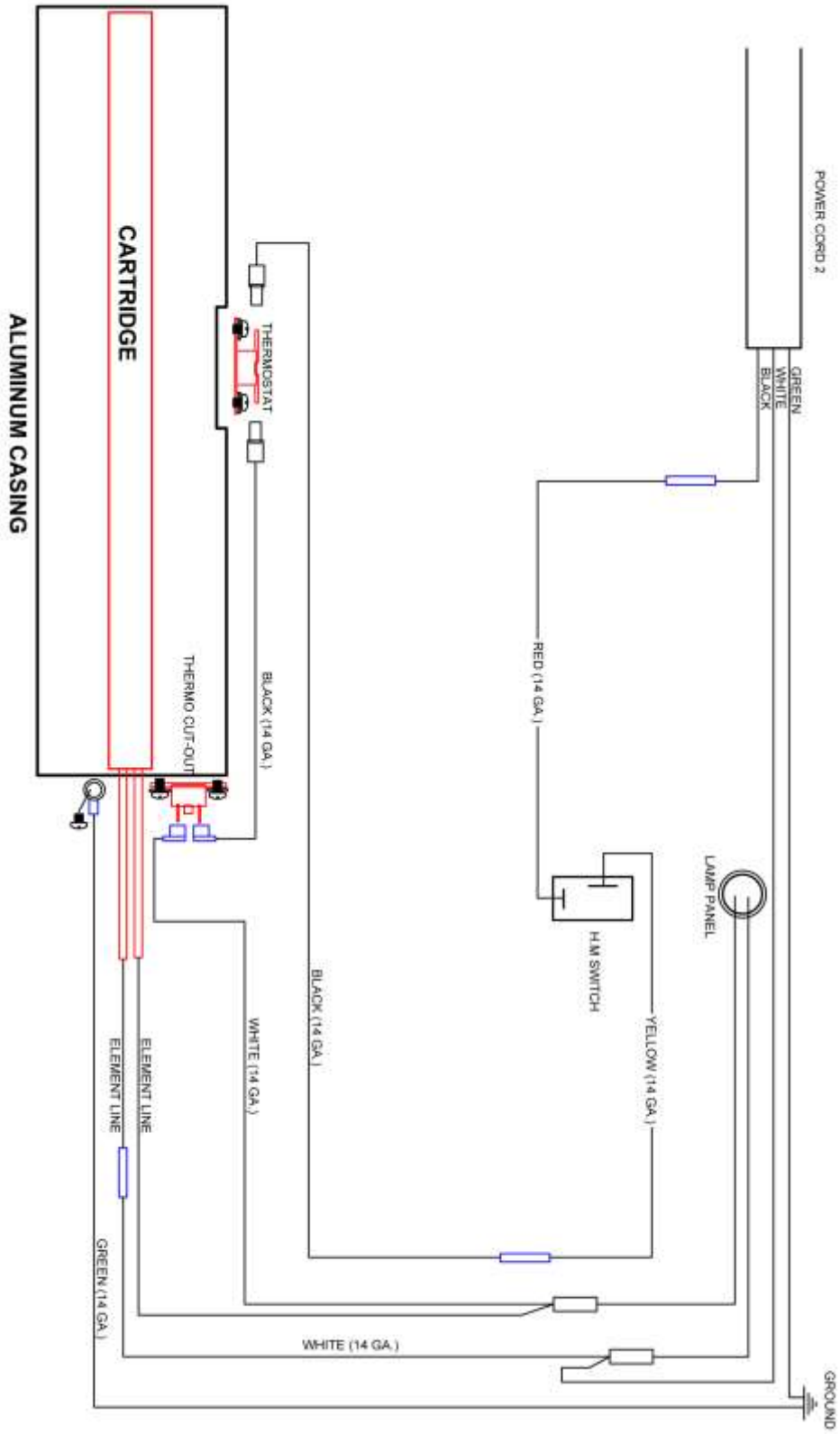



WARRANTY REGISTRATION / DELIVERY ACCEPTANCE

This form must be completed and returned to Esteam Cleaning Systems to activate your warranty.

Esteam would like to take this opportunity to point out a few operating and safety recommendations for your consideration.

* All units cords have a ground plug pin for your safety, never remove or operate any equipment if the ground pin on the plug has been removed.

* Defoamer is to be used in all machines. Improper use of chemicals will void warranty. Drycleaning solvents cannot be used in any Esteam extractors.

* Do not over fill recovery tanks as this will damage the vacuum motors. Vacuum motors showing any signs of moisture contamination will not be covered under warranty.

Model # _____ Serial # _____

Name: _____

Address: _____

City: _____ Province/State: _____

Postal Code/Zip: _____ Date of Purchase: _____
Month / Day / Year

Purchased From: _____

By signing this form I _____, accept the terms and conditions of the warranty.
(print)

I have been fully instructed in the safe operation and use of this equipment.

Signed: _____ Date: _____

Mail Warranty Registration / Delivery Acceptance to:

Esteam Manufacturing Ltd.
3750-19th Street NE
Calgary, Alberta, Canada
T2E 6V2

Or Fax to:
(403) 291 - 0546

ESTEAM® CLEANING SYSTEMS

E-Series Extractor Warranty E1700, E1000, E600, E250

NOTICE: REVIEW THIS WARRANTY CAREFULLY AS THIS DOCUMENT CONTAINS LIMITATIONS AND EXCLUSIONS.

PART I:

Esteam Manufacturing Ltd. (hereinafter referred to as "Esteam") warrants each new E-Series Extractor, subject to the limitations as defined in the specific details of its warranty coverage defined below.

LIMITED LIFETIME HOUSING WARRANTY COVERAGE:

Esteam warrants the E-Series Polyethylene Machine Housing Unit to be free from defects in material and workmanship (including cracking, leaking or deterioration) for the life of the unit, expressly subject to the limitations stated herein.

In the event a defect occurs in a E-Series Housing Unit within five years of receipt by the original customer, Esteam will, if satisfied on its examination that the failure is due to defective material or workmanship, repair or replace the E-Series Housing Unit, at no cost to the original customer, other than as maybe provided for in this warranty.

In the event a defect occurs in a E-Series Housing Unit subsequent to five years (and thereafter for life) of receipt by the original customer; Esteam will, if satisfied on its examination, that the failure is due to defective material or workmanship, provide to the original customer only, a new Housing Unit, at 50% of the then published retail pricing basis, used by Esteam.

90 DAY LIMITED WARRANTY COVERAGE:

Esteam warrants all switches, vacuum hoses and solution hoses, heatermate thermostats and thermo cut-outs to be free from defects in material and workmanship, for any defect occurring within 90 days of receipt by the original customer of the E-Series Extractor; and further subject to the limitations stated below. 90 day on labor, subject to Esteam's approval; hourly labor credit is set by Esteam.

12 MONTH WARRANTY COVERAGE:

Subject to the Limited Lifetime Warranty and the 90 Day Limited Warranty; Esteam warrants all remaining items on the E-Series Extractor to be free from defect in material or workmanship (excluding any labor charges) for a period of 12 months from date of receipt of the unit by the original customer; and further subject to the limitations stated below.

PART II - REPLACEMENT PARTS (UNDER WARRANTY)

Replacement warranty parts will be genuine Esteam parts, or parts of similar kind and quality.

All replacement warranty parts are warranted to be free from defects in materials or workmanship from the date of the original unit purchase for the balance of the original warranty period namely: 90 days, 12 months, or the Lifetime, whichever is applicable; all in accordance with the terms of Part I, of this warranty.

PART III - LIMITATIONS ON WARRANTY COVERAGE

WHAT IS NOT COVERED:

Notwithstanding any other term or covenant of Esteam contained herein, the following provisions shall apply:

- (i) No warranty is provided for any Esteam product which has failed as a result of freezing, fire, misuse, alteration, improper amps or voltage, accidental damage, improper maintenance, unauthorized repairs, alterations, abuse, neglect or operation of a Esteam product not expressly recommended or contemplated by Esteam; and
- (ii) No warranty is provided for mechanical or electrical breakdown caused by scale, hard water buildup, improper use of chemicals or resins, damage due to environmental conditions, and acts of God, or other events beyond the control of Esteam; and
- (iii) No warranty is provided for mechanical or electrical breakdown or failure of an Esteam product resulting from ordinary wear and tear, or the consequences thereof; including but not limited to the gradual reduction of the operating performance of the product. The determination of what is or is not ordinary wear and tear is at the sole discretion of Esteam; and
- (iv) No warranty is provided for damage caused by the failure of non-warranted parts and/or accessories, even if warranted parts are damaged as a result of the failure of a non-warranted part; and
- (v) No warranty is provided for damage resulting from failure by the customer to maintain scheduled maintenance requirements. The Esteam system has many parts which must either be replaced or checked for wear on a regular basis; including but not limited to replacement filters and lubricants. This system requires regular maintenance, service and attention by the customer; and
- (vi) No warranty is provided as to any extra expenses incurred by the customer, including but not limited to economic, incidental, consequential loss or damage (e.g. all labour charges, rental equipment, down time, lodging, commercial or business loss of any nature or kind due to product failure); whether direct or indirect, exemplary or punitive damage or loss, and whether in contract, tort or otherwise; and
- (vii) No warranty is provided as to failure of any cosmetic item or finish, labeling, silk screening, decals, paint, trim or other similar decorative items.
- (viii) Brass, rubber and synthetic rubber parts (e.g. "O" rings, diaphragms, gaskets, seals, grommets) are considered expendable in normal use, and are therefore not included in any warranty by Esteam.

PART IV - EXCLUSION OF LIABILITY

Esteam makes no warranties or representations, either expressed or implied, oral or written, in fact, or by operation of law, or otherwise, except as expressly stated herein as to the 90 day Limited, 12 month and Lifetime Extended warranties. Esteam, its officers, directors, agents, dealers and its affiliates (and their respective officers, directors, agents and dealers) shall not be liable to the customer nor to any party for any liability, including without limitation, strict liability, liability for loss, injury or damage due directly or indirectly to the use or operation of the Esteam product; consequential, exemplary and/or punitive damage or loss, whether in contract, tort, or otherwise.

PART V - RETURN GUIDELINES

Defective items must be replaced through a local Esteam Distributor. Replacement parts will be sent via prepaid regular ground service to the distributor. The defective part must be returned F.O.B. factory within 30 days including a letter providing the machine's serial number, date of purchase, material return authorization number, and customer name. If applicable, credit will be issued after the item has been evaluated by Esteam. Failure to comply with return policy will void the warranty on that item.

PART VI - CREDIT POLICY

All customers purchasing parts through an Esteam distributor must arrange credit directly with that distributor.

PART VII - OUTSIDE SOURCE WARRANTY REPAIRS

At the sole discretion of Esteam, it may be necessary to perform warranty/repairs at an outside source. An estimate must be submitted to and approved by Esteam prior to work being performed. Failure to do so will result in denial of your warranty claim.

PART VIII - TRANSFERABILITY

This warranty is not transferable to any subsequent owner.

PART IX - NOTICE - CUSTOMER OBLIGATIONS

- (i) Your responsibility as a customer includes but is not limited to cleaning, lubricating, seasonal maintenance (e.g. winterizing), replacement of worn parts and all regular scheduled or unscheduled maintenance.
- (ii) Any claim for warranty must be presented to Esteam or its authorized dealer, prior to the expiration of the time limitations specified and not thereafter, otherwise any warranty is void.
- (iii) Notwithstanding the generality of the foregoing customer obligations, Esteam does hereby bring to the attention of the customer, these specific maintenance operating requirements of the E-Series Extractor to validate its warranty:

(a) Chemical Warning:

Any improper use of chemicals shall void any Esteam warranty and thusly exclude any liability by Esteam. No dry cleaning chemical may be used in a E-Series Extractor; - as any such use may result in fire or pump/motor damage. A defoamer solution must be used bycustomer to limit foaming in the recovery tank.

(b) Vacuum Motors:

Require use of a defoamer. A vacuum motor showing moisture contamination on interior components shall void any warranty by Esteam.

(c) Pumps:

All pumps require daily flushing with clean water after use.

(d) Internal Heatermate:

The internal heater must be flushed with clean water after every use. Any build up of hard water deposits or chemical build up within the internal heater will void any Esteam warranty thusly exclude any liability of Esteam.

The foregoing constitutes Esteam's entire warranty and no other warranty, liability, contingency or responsibility, direct, indirect, consequential or in any other way connected with the sale or operation of Esteam machines or chemical product is expressed or implied.

E-Series Extractor Warranty
Esteam Manufacturing Ltd. 3750-19th Street NE
Calgary, AB T2E 6V2 1-800-653-8338